



FUJIKURA COMPOSITES

PRECISION VACUUM REGULATORS

RV

SERIES

▶ Air Regulators that attain High Accuracy in Vacuum Pressure Regulation.



FUJIKURA COMPOSITES Inc.



PRECISION VACUUM REGULATORS

■ Features

● Accurate Vacuum Control

Sensitivity : 1 Torr (0.13kPa)

Repeatability : Within ± 2.2 Torr (± 0.3 kPa)

● Superior Source Vacuum Sensitivity

Set vacuum pressure variation to changes in source vacuum pressure : Within 10 Torr (1.3kPa)

● Large Flow Capacity

Flow capacity up to 270 NL/min allows wide uses in high flow applications.

● Good Responsibility

Quickly responsive to minute changes in output vacuum pressure.



■ JIS symbol

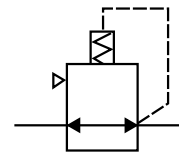

■ Specifications

Item	Model	RV·S-1-2	RV-1-2	RV-1-3
Working Fluid		Air (Vacuum)		
Vacuum Range Setting	kPa(mmHg)	-1.3 ~ -100 (-10 ~ -750)		
Output Sensitivity	kPa(mmHg)	0.13 (1)		
Repeatability	kPa(mmHg)	Within ± 0.3 (± 2.2)		
Operating Temperature	°C	5 ~ 60		
Flow Rate	NL/min(normal)	200	270	
Port Size		Rc1/4		Rc3/8
Accessory Parts	Bracket (Standard)			
Weight	kg	0.5	0.65	

■ Explanatory construction and Principle of operation

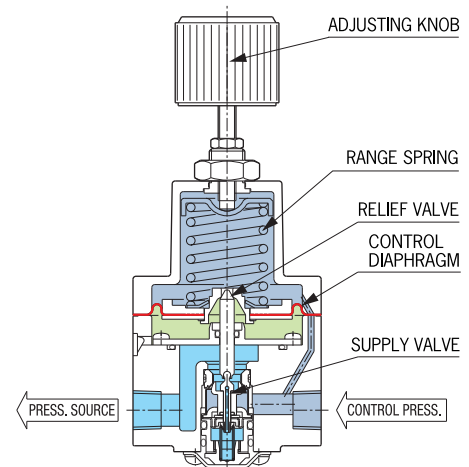

Main and Exhaust valve device of balance type keeps secondary sensitivity very low to changes in source vacuum pressure.

Clockwise turning of Control knob opens Main valve, causing rise in secondary vacuum pressure, and vice versa.

Secondary vacuum pressure acts on Diaphragm to exert upward force and balances downward force of Range spring, creating an output set vacuum pressure.

Slight rise/fall in output vacuum level above/ under the set point will move Diaphragm upward/downward, causing Exhaust/Main valve to open until the set point is again reached.

< MODEL DESIGNATION >

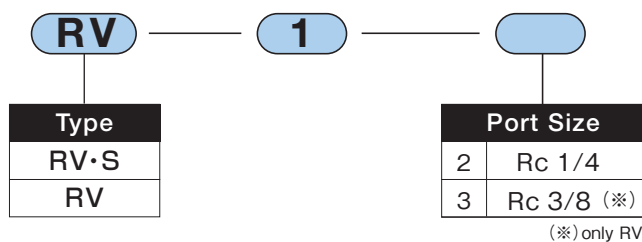

Characteristic

RV-S

Pressure Characteristic

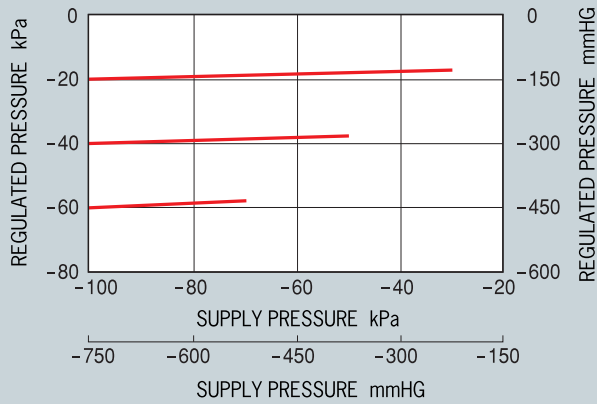

Flow Characteristic

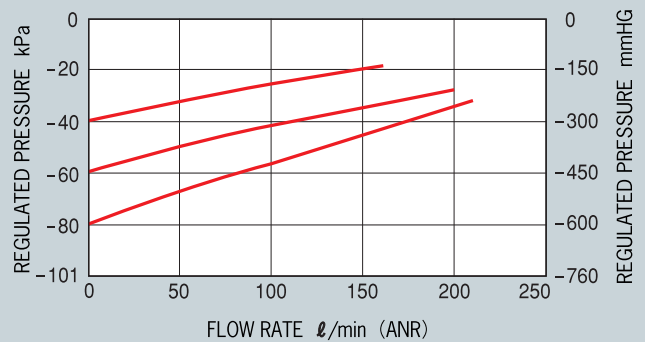

RV

Pressure Characteristic

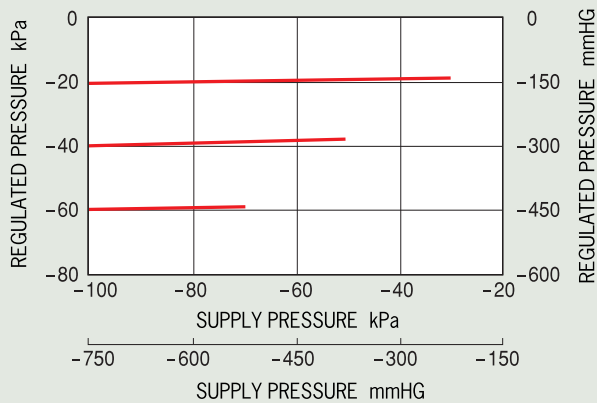

Flow Characteristic

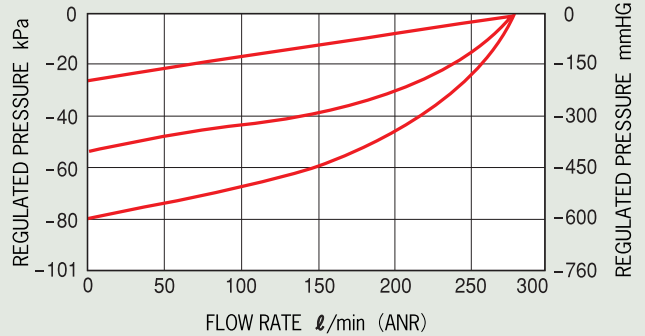

CAUTION

- ① Flush out all air lines thoroughly to remove dirt and scale before installation is made.
- ② When plumbing connections, apply seal tape onto male threads starting with 3rd thread back away from end to avoid possibilities of getting the tape into Regulator and air line.
- ③ Before a vacuum pressure is applied to Vacuum Regulator, turn Control knob full counterclockwise to loosen. After that, apply vacuum pressure to the system and turn knob clockwise as required to set necessary vacuum pressure.

WARNING

- ④ Do not torque excessively Tightening screws when attaching Mounting bracket to Body.
- ⑤ Additional 2 ports of Rc(PT) 1/4 other than plumbing ports are provided for vacuum pressure source (vacuum pump side), but not for pressure gauge.



RV-S

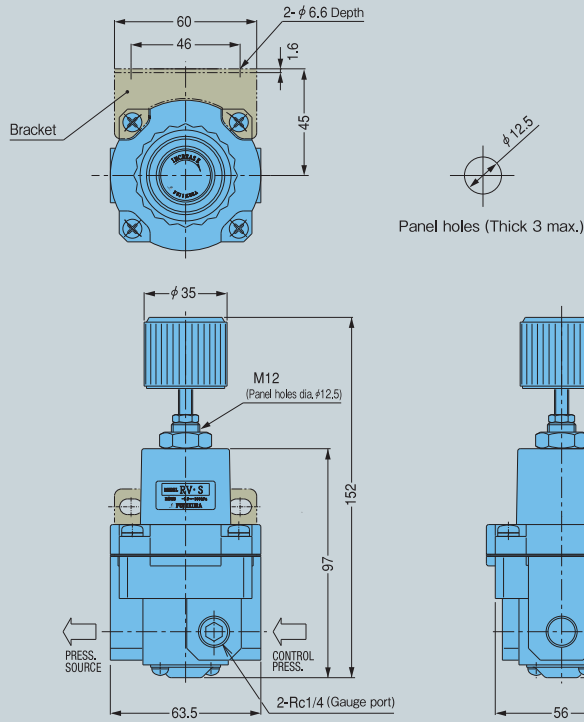

RV

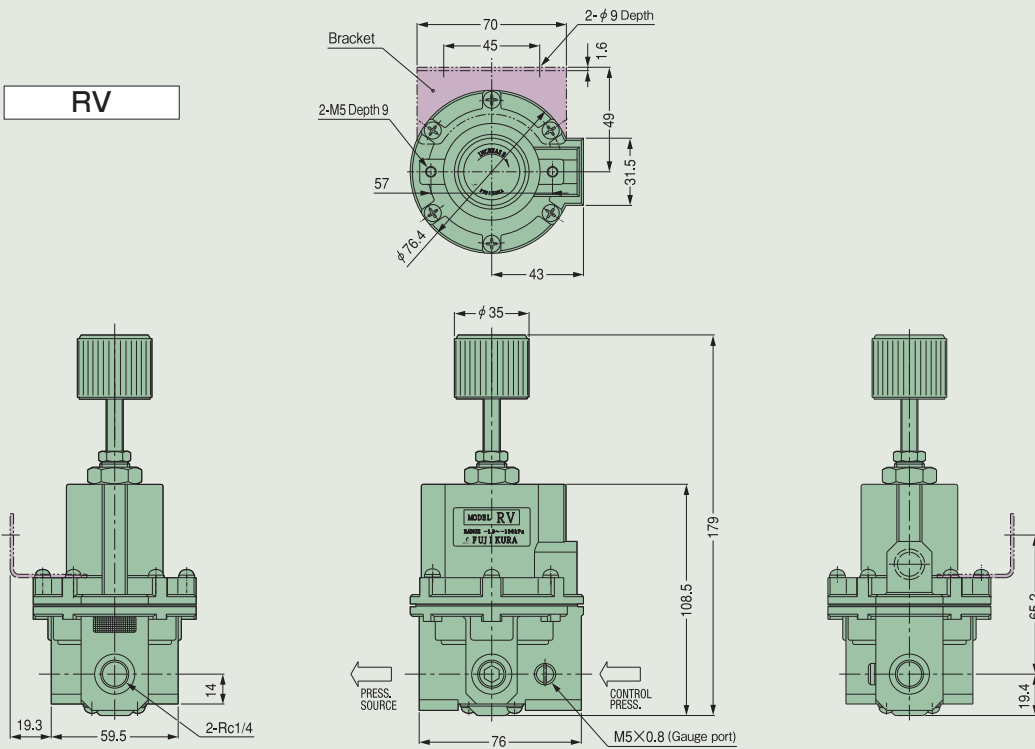

Control Equipment Sales Department

10F, TOC Ariake East Tower

3-5-7, Ariake Koto-ku, Tokyo 1350063, JAPAN

TEL: +81-3-3527-8573 FAX: +81-3-3527-8390

Email: seigy.toiawase@fc.fujikura.co.jp

URL: <https://www.fujikura-control.com/english/>

Notice: Specification changes of Accessory (Bracket for regulator “RV-S series”)

We hereby give official notification that the specifications of the bracket for air regulator “RP series” and “RV series” you have purchased from us are changing from the first lot of production in April 2023. There will be no change in product model number due to this change.

【Details of change】

The shape will be changed in accordance with the shared use with other regulator series. Due to the change in shape, the mounting position will also change. There are no changes to the products themselves, so there are no effects on the characteristics.

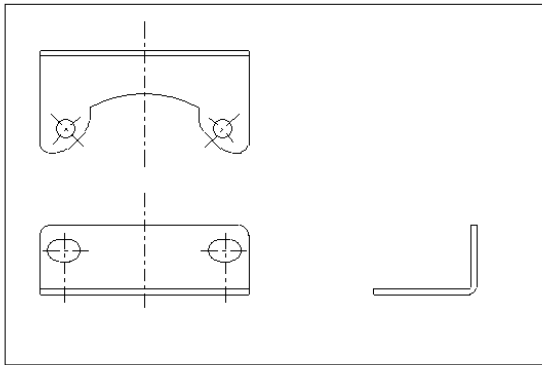

Bracket
Previous model

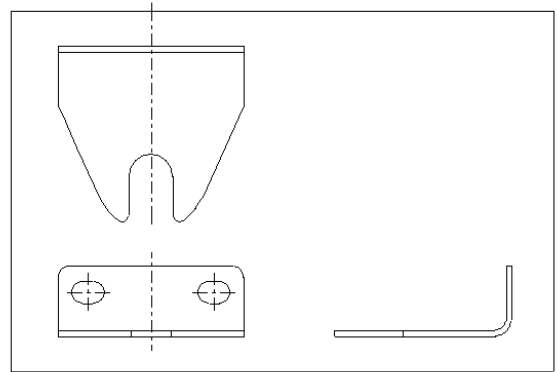

Bracket
New model

【RV-S series】

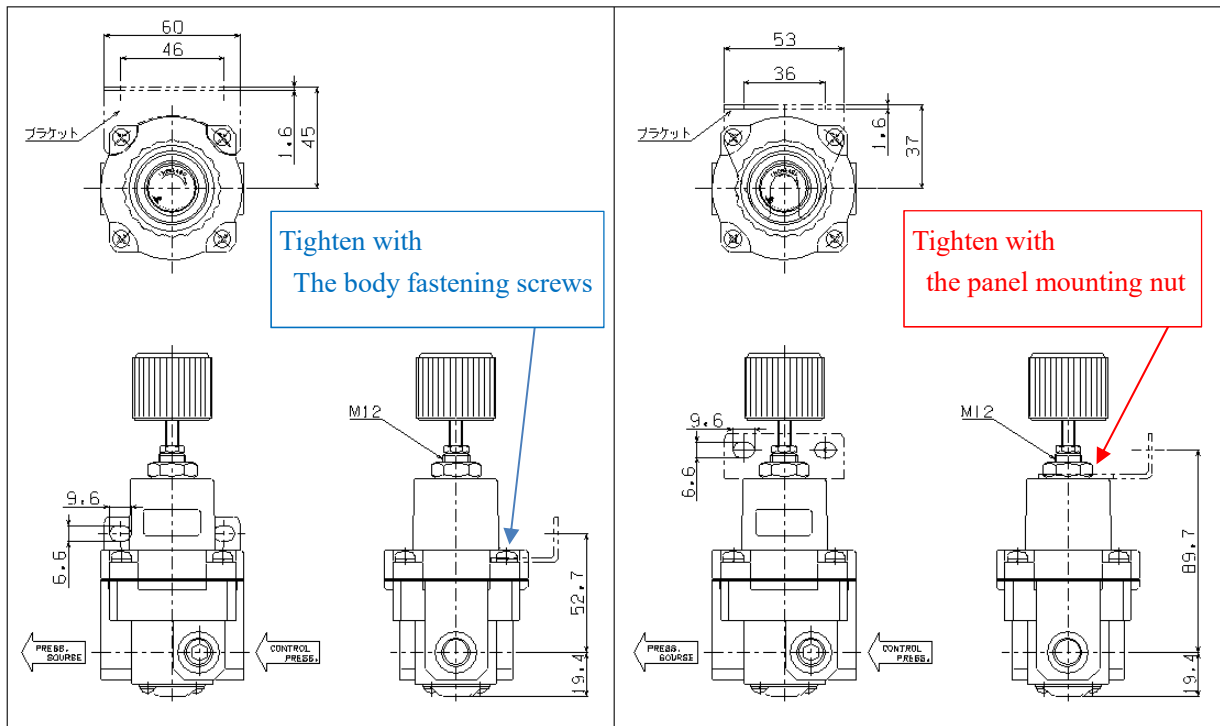

Assembly Drawing
Previous model

Assembly Drawing
New model

管理番号: CES20-22-008E